

| POLE CAT. NO. | SHAFT SIZE |
|---------------|------------|
| | A |
| 105-5018-18 | 5.0" SQ. |
| 105-5018-20 | 5.0" SQ. |
| 105-5018-25 | 5.0" SQ. |

NOTE: BOLT PROJECTION RANGE ABOVE FOUNDATION
2.50 MIN.-3.00 MAX WHEN LEVELING NUTS
AND GROUT ARE USED.

SET ANCHOR BOLTS AT Ø10.50 BOLT CIRCLE.

WARNING: THE FACTORY WILL NOT HONOR ANY CLAIM FOR INCORRECT ANCHORAGE PLACEMENT CAUSED FROM FAILURE TO USE FULL SIZE, FACTORY SUPPLIED TEMPLATES. IT IS POSSIBLE FOR DOWNLOADED FILES TO BE DISTORTED WHEN PRINTING FROM WEBSITE. IT IS THE CONTRACTORS RESPONSIBILITY TO VERIFY ACCURATE MEASUREMENTS.

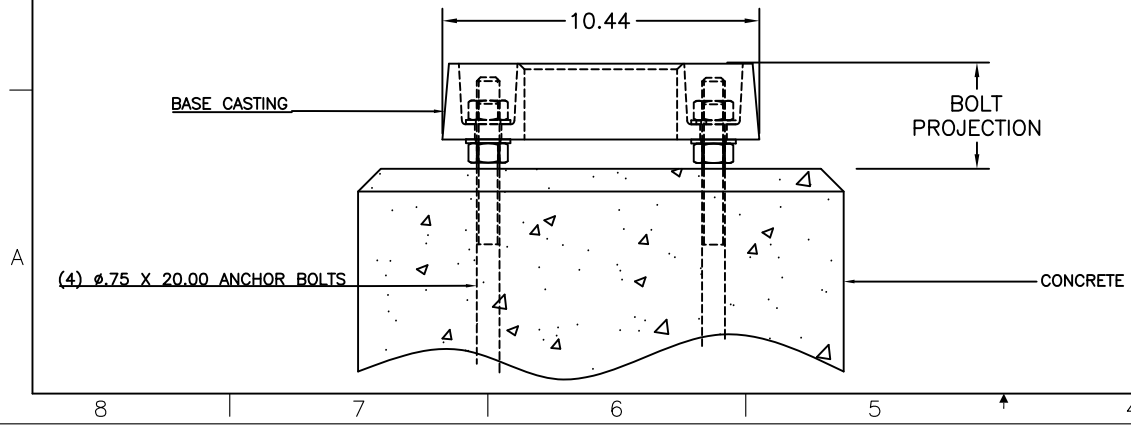

| | | | |
|----------------------|------------------|--|--------|
| DRAWN: M. HARVALA | DATE: 3-12-09 | LYTE POLES, INC. P.O. BOX 340 EASTPOINTE, MI 48021 | |
| CHECKED: | | TITLE: T-2A Ø10.50 B.C. | |
| QA: | | | |
| MFG: | | | |
| APPROVED: | | | |
| | SIZE: D | DWG NO: T-2A | REV: B |
| | SCALE: | SHEET: 1 OF 1 | |